

blue ARROW
Engine Interface Module

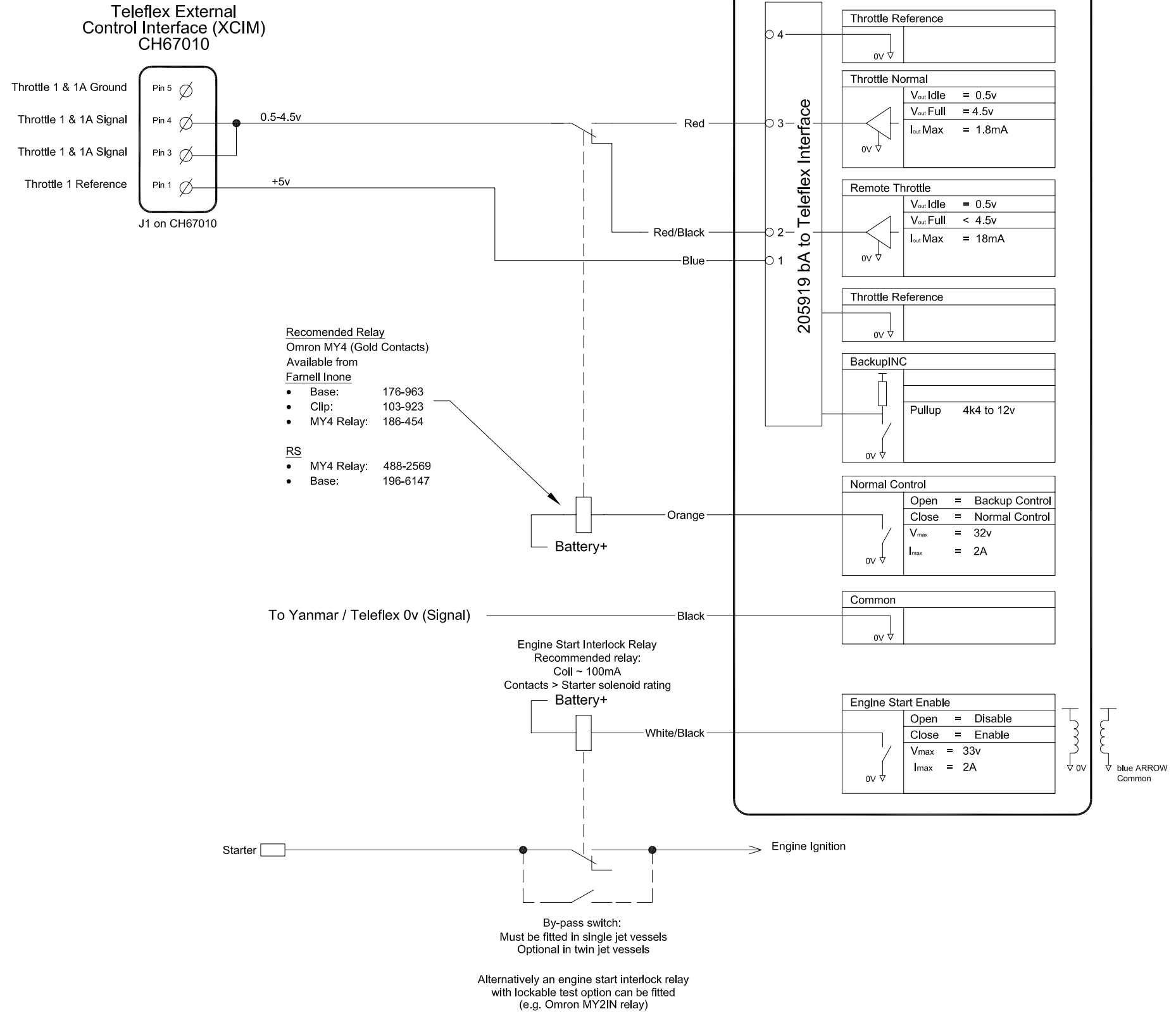

Make	Model	Feedback Type	Demand Type	Min RPM	Max RPM	Volt Min	Volt Max	Eng Dmd Mode	Eng Dmd Low	Eng Dmd High
Yanmar	6LY3-STP	Jet	Voltage	700 [#]	3300 [#]	5	46	Voltage	1330*	12300*
Yanmar	6SY-STP	Jet	Voltage	#	2300 [#]	5	46	Voltage	1330*	12300*
Yanmar	6BY260	Jet	Voltage	#	4000 [#]	5	46	Voltage	1330*	12300*

* Initial values only. Adjust values during installation to achieve correct level.
Engine RPM is affected by specific waterjet selection. If gearbox fitted, adjust to give jet shaft RPM.

C. W. F. Hamilton & Co. Ltd Christchurch, New Zealand

AMENDMENT		MATERIAL	Certified	Weight (kg)	✓ = N9 EXCEPT AS STATED
ENGINE INTERLOCK BY PASS SWITCH ADDED				Cast	UNLIMITED DIMENSIONS TO BE ±0.5
				M/C	Scale
		DESCRIPTION			
		blueARROW			
		ENGINE SCHEMA H			
		CONFIGURATION			
ECN	CL576	BY	F.K.	DATE	09.06.09
JET				Name	Date
				R.L.	22.01.07
This print is provided on a restricted basis and is not to be used in any way detrimental to the interests of C. W. F. Hamilton Ltd					Reviewed
					DWG No 205953

DWG No 205953