

Single Jet Power Supply Arrangement

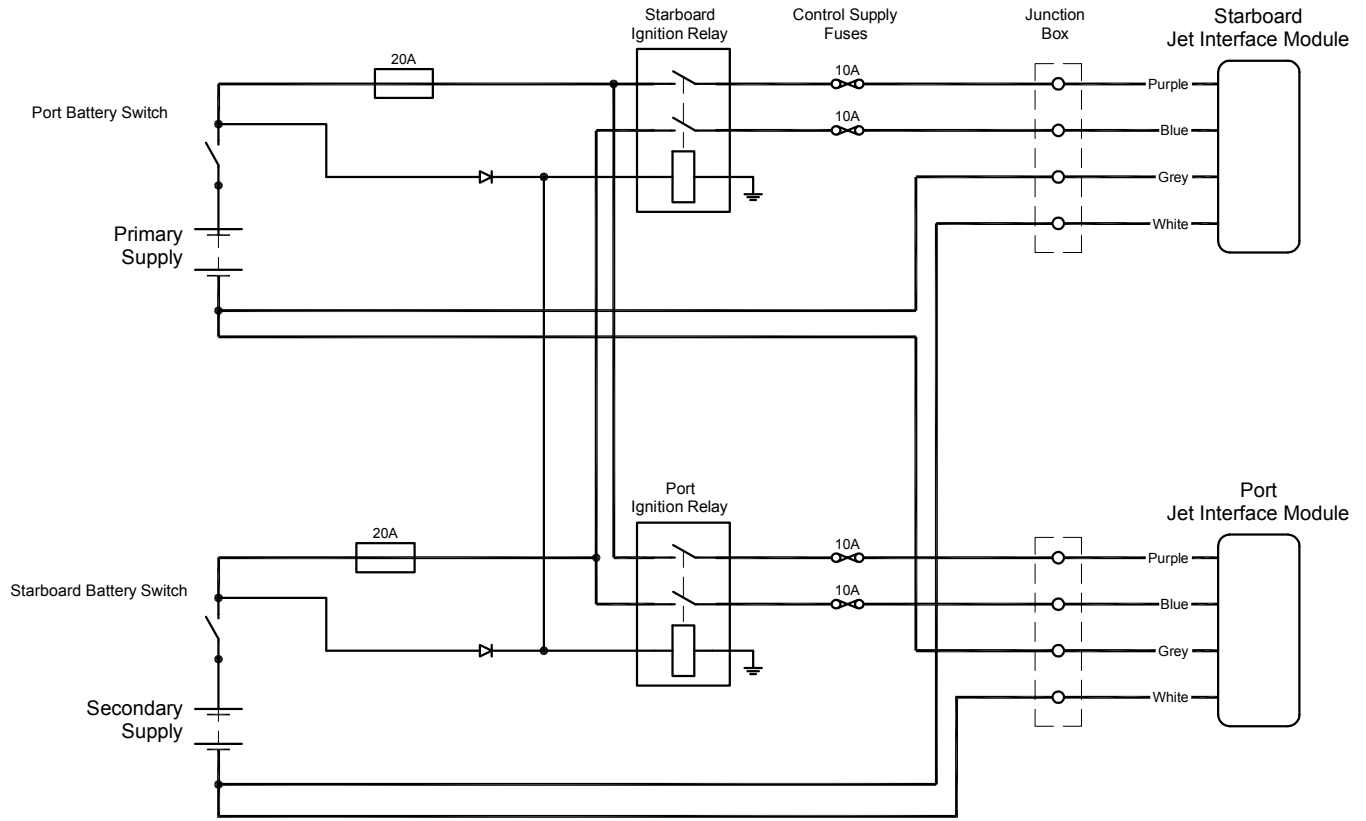

Twin Jet Power Supply for Volvo Engine

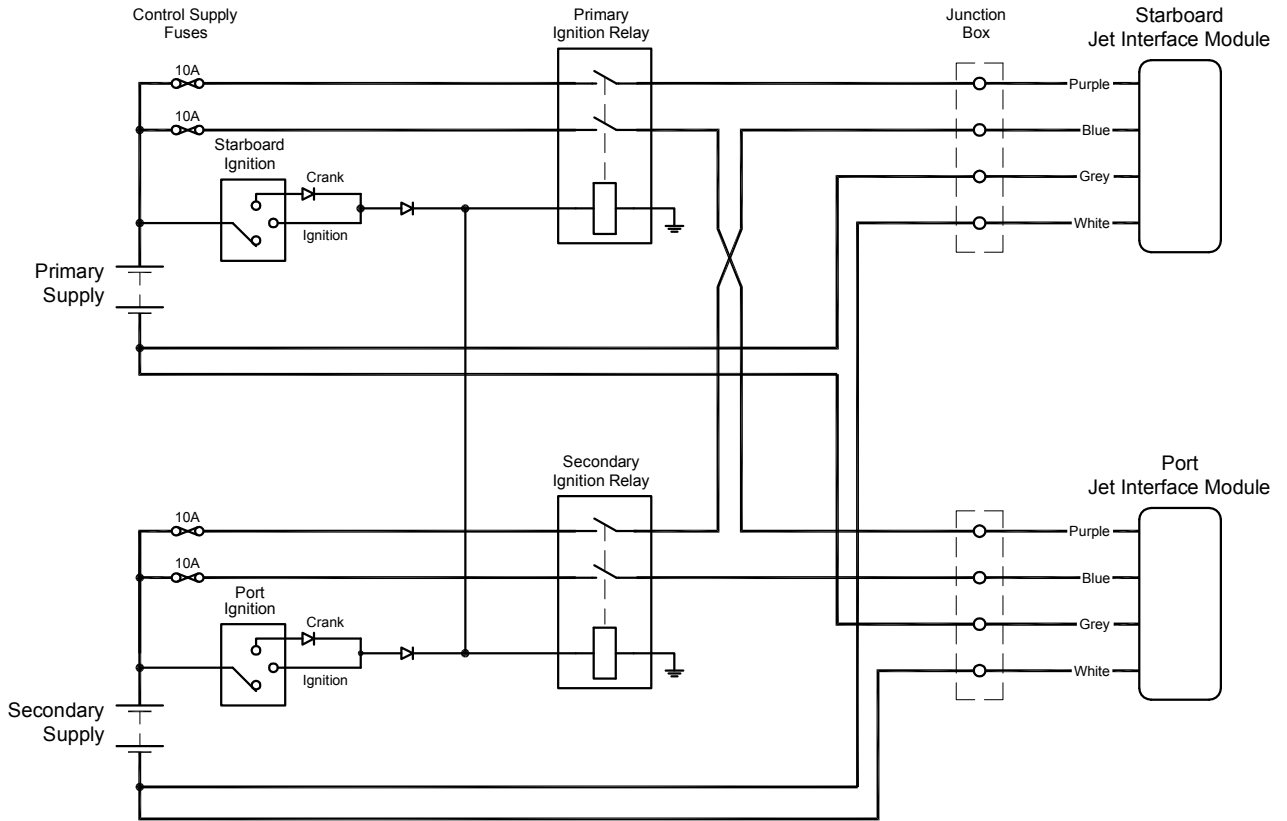

Twin Jet Power Supply Arrangement

C  
DWG No 204937

Note:  
blue ARROW must have separate and independant  
Primary and Secondary power supplies.

C. W. F. Hamilton & Co. Ltd Christchurch, New Zealand									
AMENDMENT				MATERIAL		Weight (kg)		✓ = N9 EXCEPT AS STATED	
C - CIRCUIT DIAGRAM ADDED.				Certified		Cast		UNLIMITED DIMENSIONS TO BE ±0.5	
B - SINGLE JET ARRANGEMENT ADDED						M/C		Scale	
WIRING MODS TO TWIN JET ARRANGEMENT								DESCRIPTION	
				Standard				blueARROW RECOMMENDED	
				Approvals				POWER SUPPLY SCHEMA	
ECN	CL662	BY	J.S.R	DATE	14.03.11	Name		Date	
JET						Designed		16.12.05	
				Reviewed				DWG No 204937	
This print is provided on a restricted basis and is not to be used in any way detrimental to the interests of C. W. F. Hamilton Ltd									